



- The well known model of the small sized CO₂ cutting and marking series featuring cutting edge technology providing flexible operation with high performances and safety.
- The **Eureka** structure is composed of a coated electro welded metal sheet mono-block.
- High Performances: up to 2000mm/s speed with 2 G acceleration.
- X-Y motorized axes with micro-brushless motors and belt transmission.
- Cutting head with lens holder and interchangeable focal unit and nozzle.
- Work table with motorized Z axis, aluminium honey comb supports and pre-arrangement for suction.
- Rear and front opening for processing long slab material.
- "Icaro" software (CAM) stamps and bas reliefs are also possible via a raster mode with 0-255 gray scales.



CCD kit for register cutting with print marker recognition



Additional cutting head for dual work process



Focal unit set : interchangeable optics and focal units



Additional flange for suction



360° rotary attachment

Main technical features:

CO ₂ sealed laser source	power available from 30 W to 150 W
Work area (mm)	610 x 460
Max. vertical range of the motorized work table	0-240
Nozzle/head clearance mm	240
Repeatability (mm)	+/- 0,05
Resolution X-Y axes (mm)	0,002
Max. acceleration (m/s ²)	20
Max. vector speed (mm/s)	2000
Max. raster speed Y axis (mm/s)	2000
Max. resolution bitmap (dpi)	1200
Max. gray scale bitmap file	256
Interface software	CAM Icaro on Windows™ platform
File compatibility vector	.dxf; .plt (hpgl); .ai; .eps; .pdf
File compatibility matrix points	.bmp; .jpg; .tiff; .wmf; .pcd; .pnt; .pcx; etc.
Norm compliance	2006/95/CE Low Voltage Directive 2006/42/CE Machinery Directive 2004/108/CE Electromagnetic Compatibility Directive IEC EN 60825-1 Laser Safety



Options available increasing flexibility:

- kit for register cutting with print marker recognition: optic CCD+software;
- 360° rotary axis for marking and/or cutting cylindrical objects;
- additional cutting head for dual work process;
- additional kit for compressed air assist to aid cutting and/or marking;
- 3D kit for cutting/creasing and kiss - cutting of 3D surface - materials (compatibility*.dxf 3D);
- focal units and lens holders available: 1,5"; 2"; 3".

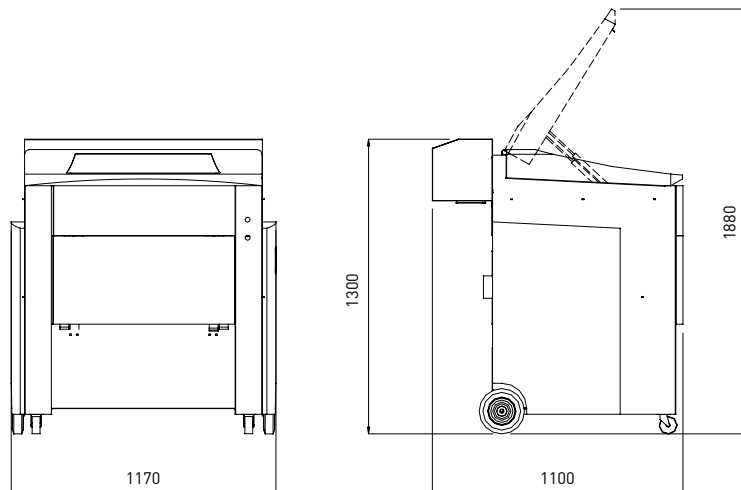

Kg 250 max.

The system is CE certified.
The features and the specifications of the system may change without notice.